



■ *An Innovative Design, Built To The Highest Standards To Meet and Exceed The Customer's Demands.*

KEY FEATURES

- High performing, fuel efficient 56 hp ISUZU water cooled diesel engine
- 4 - 13 foot paving width
- Full width floating screed, adjustable, vibrating and heated.
- High capacity, 7.5 ton hopper area
- 2 - Speed travel performance:
 - 0 - 160 fpm paving speed
 - 0 - 320 fmp travel speed



Dual Operator's Positions Provide Controllability From Either Side

Fully Enclosed 56 hp ISUZU Water-Cooled Diesel Engine

Hydraulically Actuated, 3/8" Material Thickness Hopper Wings

7.5 Ton Hopper Capacity

4 - 13 Foot Full Paving Width

Dual 24" Independently Controllable Conveyors Manual, Automatic and Reversing

13" Wide x 70" Long Hydrostatic Track Drive System

■ *4410 Will Tackle Your Toughest Jobs...*

The 4410 offers compaction and finishing of the entire width of the mat, not just on the main screed. These series machines are some of the most powerful machines in their class with a standard 56 engine horse power rating and load sensing hydraulics. With its load sense hydraulic system, the machine distributes power when needed so engine horse power is not wasted. The 4410 machines can tackle the toughest jobs with power to spare.

■ **Applications:**

- Secondary roads and city streets
- Driveways
- Parking lots
- Asphalt repairs and resurfacing



The 4410 Machine paving a side street.



Larger capacities and paving widths

■ LARGE HOPPER DESIGN:

The 4410 hopper bed holds 7.5 ton of asphalt if loaded from a truck. More material can be handled if loaded by a skidsteer or front end loader. The 3/8 in thick hopper wings are robust and can withstand abuse without bending and folding like the competition. The 4410 hopper has been designed to facilitate easy clean up. The floor does not raise, as the major drive components are located outside the paving machine. The low profile design of the 4410 machine will facilitate loading from most any truck or hauling vehicle without problem.

■ 4 TO 13 FOOT FULL WIDTH PAVING:

The 4410 offers compaction and finishing of the entire width of the mat, not just on the main screed. Screed wear plates are 400 Brinell hardness bolt on replaceable. The hydraulic screed extensions are single ratcheted adjusting both the height and attack angle in one turn of the crank. Heavy consideration has been given to the operator on these machines as the upper platforms are cushioned in rubber, and the lower walk boards are extendable.

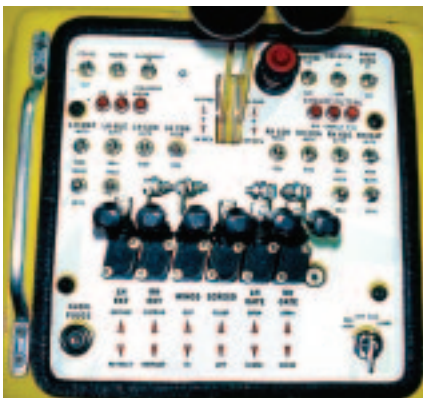

Propave 4410 Controls

■ 4410 Controls:

- Manual hydraulic valves
- Controllability from both sides of machine
- Ease of operation



The 56 horse power ISUZU diesel engine is protected by a high water temperature, low oil pressure shut down system.



Autodepth option fully controls mat thickness when in the automatic mode.



Full floating screed with (2) 30" hydraulically operated, adjustable screed extensions.

With these features and many more, it's easy to see why this model maintains a high residual value while delivering lower lifetime operating costs.

Technical Specifications

4410

Shipping dimensions
in cubic feet (m³)
4410

663 (18.8)

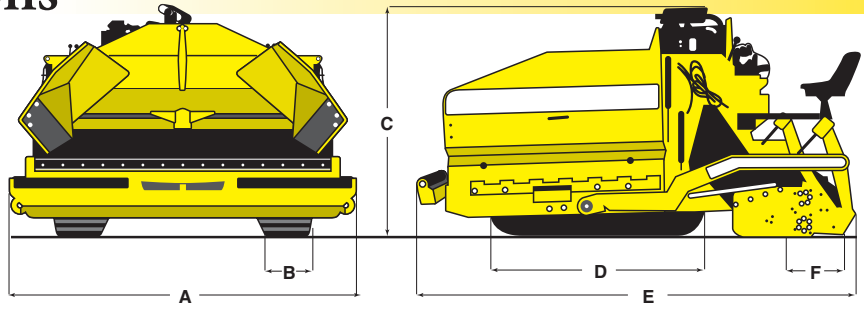

Standard Equipment

- 56 hp ISUZU Water-Cooled Diesel Engine
- High Engine Water Temperature, Low Engine Oil Pressure Automatic Shutdown
- Hydrostatic Positive Sprocket Track Drive System - 70" Long
- Hydrostatic Drive with Load Sensing Design
- Dual Operator's Stations
- Full Width Floating Screed, Adjustable, Vibratory and Propane Heated
- Hydraulic Screed Extensions with 1/4" Abrasion Resistant Wear Plates
- Large Capacity 7.5 Ton Hopper Area
- Dual 24" Material Conveyors with Automatic/Manual Controls
- Hydraulic Shut-off Gates, 2 Each
- Washdown Spray System

Optional Equipment

- Swivel Mounted Bumper Rollers
- Hydraulic Truck Hitch
- Screed Automation
- Power Depth Controls
- Hand Held Screed Remotes
- Mega Feed Dual Auger System
- Seat(s)
- Spraydown Hose Reel

DIMENSIONS IN INCHES (MM)

	A	B	C	D	E	F
4410	102 (2591)	13 (330)	78 (1981)	70 (1778)	144 (3658)	15 (381)

Technical data

Weights

Operating Weight lbs (kg)

Dimensions

Length in (mm)
 Width (Transport) in (mm)
 Paving Width ft (m)
 Overall Height in (mm)
 Paving Depth in (mm)

Hopper

Capacity tons (tons)
 Wings
 Deck

Screed:

Standard ft (m)
 Type

Crown / invert in (mm)
 Vibratory vpm

Speeds:

Travel fpm (mpm)
 Paving fpm (mpm)

Drive:

Engine Type
 Performance SAE J1349 hp (kW)
 Cooling
 Fuel

Service Capacities:

Fuel gal (l)
 Cooling gal (l)
 Hydraulic gal (l)

ProPaver 4410

12000 (5443)

144 (3658)
 102 (2591)
 4 - 13 (1.2 - 4.0)
 78 (1981)
 0 - 6 (0 - 152)

7.5 (8.4)
 Hydraulic Actuated
 Fixed

4 - 13 (1.2 - 4.0)
 Full Float, Adjustable
 Vibrating & Heated
 2 / 2 (51 / 51)
 2500

0 - 320 (0 - 98)
 0 - 160 (0 - 49)

ISUZU
 56 (41.8)
 Water
 Diesel

Technical modifications reserved. Machines may be shown with options.

BOMAG
FAYAT GROUP

BOMAG Paving Products
 618 N. Enterprise Dr. • Warrensburg, MO 64093
 Tel: 660 422-4272 • Fax: 660 747-7545